

OPERATION & MAINTENANCE MANUAL

eco-DUO600



1	Introduction	4
1.1	Delivery package	4
1.2	Incoming inspection	5
2	Safety	6
2.1	Explanation of symbols used	6
2.2	Intended use	7
2.3	Personnel.....	8
2.3.1	Operators.....	8
2.3.2	Maintenance staff	8
2.4	Informal safety precautions.....	8
2.5	Preventing damage to equipment.....	9
2.6	Organisational safety measures	9
2.7	Residual risks.....	10
2.8	Transport and storage.....	11
3	Product description	12
4	Operation	13
4.1	Initial commissioning.....	13
4.1.1	Dismantling the dispenser	13
4.1.2	Installing the stator.....	15
4.1.3	Reassembling the dispenser	16
4.1.4	Information on the sensors	17
4.1.5	Connecting the dosing unit to the drive unit.....	18
4.1.6	Feeding material and bleeding the dispenser for the first time..	19
4.1.7	Calibration.....	20
4.2	Switching on, starting dosing process.....	20
4.3	Recommendations for problem-free operation	21
4.4	Switching off, ending dosing process.....	22
4.5	Decommissioning.....	23
4.6	Re-commissioning	23

5	Maintenance	24
5.1	Maintenance intervals	24
5.2	Troubleshooting	25
5.3	Stator change.....	26
5.4	Dismantling before cleaning.....	27
6	Cleaning	28
7	Spare parts	29
7.1	Item list of the spare parts.....	29
7.2	Overview drawing of the spare parts	31
8	Technical specifications.....	32
8.1	Installation declaration	32
8.2	Technical data.....	33
8.3	Materials used.....	34
8.4	Dimensions	34
9	Disposal	35
10	Accessories	35

1 Introduction

Dear customer,

We are delighted that you have decided to purchase a ViscoTec product. We have no doubt that this product will meet all your requirements. We wish you trouble-free and successful operation.

The dosing system consists of the eco-DUO600 dispenser and the eco-CONTROL EC200 DUO dosing control unit or the plug'n'mix dosing control unit.

The eco-DUO600 dispenser is described in this operation manual. A separate operation and maintenance manual is enclosed with the dosing control unit.

1.1 Delivery package

The scope of supply includes:

- 1 dosing unit (A)
- 2 stators (B)
- 2 eco-PEN600 drive units (C) with connection cable (1.5 m)
- 1 assembly aid (D)
- 2 screwdriver (E)
- 2 allen wrench (F)
- 1 calibration adapter (G)
- 1 fastening set (2 rear plates) (H)
- 1 mixer set (3 static mixers) (I)
- 1 Operation & maintenance manual

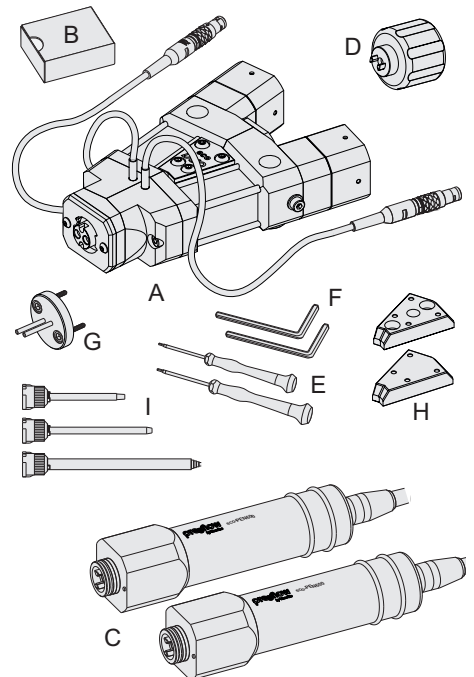

Fig. 1

1.2 Incoming inspection

Damage in transit can lead to malfunctions, and consequently to personal injury and damage to property. Damaged components must not be put into operation.

Check the delivery immediately on receipt for damage in transit and damage to the packaging. Check that the delivery is complete according to the enclosed delivery note. Make sure you have not left any part of the delivery in the packaging.

Compensation for damage during transport may be claimed only if the carrier is notified immediately.

2 Safety

2.1 Explanation of symbols used

The following symbols are used in this manual:

-  Work step
- List
- Fig. 1 Legend number, reference to a figure
- * Reference to a comment
- COMMAND** Designations of buttons/switches, menu items and input dialogs

The following notices indicate safety instructions and must be followed:



indicates a hazardous situation which, if not avoided, will result in death or serious injury.



indicates a hazardous situation which, if not avoided, may result in death or serious injury.



indicates a hazardous situation which, if not avoided, may result in minor injury.

NOTE

indicates a technical tip to avoid damage to property or equipment.

This manual is structured so that text and the related figure are on the same page as far as possible. In this way the information can be understood quickly. If reference is made to a component in a figure, the part has a key number.

2.2 Intended use

The eco-DUO600 dispenser is used to feed and precisely dose viscous materials.

The dispenser is controlled using the eco-CONTROL EC200 DUO dosing control unit or the plug'n'mix dosing control unit.

Check the chemical resistance of the materials that are in contact with the material before commissioning. Information on the materials can be found in the order confirmation or in Section 8.3 "Materials used" (page 34).

No liability can be accepted for damage caused by failure to observe this operation manual or due to a lack of maintenance or checks.

Misuse

Any use other than the stipulated intended use shall be considered as misuse.

This includes

- use outside the permissible operating limits
- use in explosive environments
- use underground
- use outdoors

Misuse also includes the following actions carried out without the explicit written approval of the manufacturer:

- Conversions and/or extensions
- Use of non-original spare parts (e.g. rotor)
- Repairs carried out by unauthorised companies or persons
- Use of non-approved materials

Misuse is not permissible, and will result in voiding of guarantee, warranty and liability claims.

2.3 Personnel

The operating organisation shall ensure that only appropriately qualified and authorised personnel work on this machine. It is responsible for ensuring that operators and maintenance staff possess the necessary qualifications. Personnel must be at least 15 years old.

All personnel working with or on the machine must have read and understood this operation manual.

The operating company shall document the operators' and maintenance staff's acknowledgement of this manual, and shall ensure their compliance with it by means of regular training.

2.3.1 Operators

Before starting work, the personnel assigned as operators must be adequately instructed regarding the nature and scope of their duties and the potential risks. Training shall be conducted on a regular basis (at least once a year). Training shall be conducted after any technical modifications.

2.3.2 Maintenance staff

The maintenance and repair staff must be authorised and

- adequately trained for the relevant activities
- familiar with and comply with the applicable technical rules and safety regulations

Competent personnel are persons who, by virtue of their training, experience and knowledge of the relevant requirements, standards and safety regulations, can carry out the necessary activities while recognising and avoiding potential hazards.

2.4 Informal safety precautions

The following documents must be read, understood and followed. They must always be available at the machine's operating location, and must be kept in legible condition:

- The operation manual for this product
- Generally applicable and local accident prevention and environmental protection regulations
- Safety data sheets for the conveyed materials, as well as for any cleaning products or lubricants being used

2.5 Preventing damage to equipment

In order to prevent damage to equipment and to ensure precision dosing, note that

- the dispenser must never be operated without material (the stator will be destroyed)
- the material inlet (feed) and the material outlet must never be closed during operation
- the material outlet (e.g. dosing needle or mixer) must not be damaged or blocked
- the dispenser is operated with a positive feed (inlet pressure)
- there is adequate inlet pressure when conveying highly viscous material
- when pumping without a positive feed (inlet pressure), no dry running or cavitation of the dispenser occurs
- the direction of rotation of the drive is always the same as the direction of flow of the dispenser
- the specifications in the product data sheet for the material are observed and adhered to

2.6 Organisational safety measures

The necessary personal protective equipment must be provided by the operating organisation. Personal protective equipment must be worn when carrying out all work and procedures.

To ensure the provision of suitable personal protective equipment, the safety data sheet for the conveyed material must be observed. Specifications for e.g. cleaning products and lubricants must also be checked and observed.

All personal protective equipment must be checked to ensure it is working properly before starting work.



Eye protection



Hand protection



Body protection



Foot protection

2.7 Residual risks

Thorough training, observance of the operation manual and compliance with safety regulations are key to permanently accident-free operation.

The following residual risks may occur when operating this machine:

WARNING

Material hazardous to health

The conveyed material may contain constituents which are hazardous to health.

Such constituents may cause serious acute or chronic harm to health if they come into contact with skin, are inhaled or swallowed.

- Always wear appropriate protective equipment
- Observe the specifications in the safety data sheet for the material

WARNING

Risk of injury from moving components

The machine is driven by an electrical drive unit. These generate very high forces.

Touching the components during operation may result in serious injuries.

- Do not operate the machine unless there is unrestricted visual contact with the moving component
- There must be no persons or foreign objects in the danger area

WARNING

Pressurised material

Depending on the setting of the machine, the material is conveyed under very high pressure. If the delivery rate is not adapted to the dosing needle being used,

unwanted spraying of the material might occur. This may result in serious injury.

Defective components can also cause spraying.

- Shut down the machine immediately
- The leak must be repaired by qualified maintenance staff before operation is re-started

⚠ CAUTION**Splashing material**

During initial commissioning and after being refilled, air bubbles in the material could cause an uncontrollable spraying from the conveying area. This may result in injury.

- Always wear appropriate protective equipment
- Fully bleed the system before start of production

⚠ CAUTION**Pointed dosing needle**

Depending on its size, the dosing needle can be very thin and pointed. Carelessness during assembly work can lead to needle stick injuries.

- Carry out assembly work with appropriate care.

2.8 Transport and storage

The following ambient conditions must be observed for transportation and storage:

- Temperature within the range -10 °C to +40 °C (263 K to 313 K)
- Relative air humidity less than 60 % (non-condensing)
- Uniform room climate
- Dry and free of dust
- No exposure to direct sunlight
- No aggressive, corrosive substances (solvents, acids, alkalis, salts, etc.) in the environment

For storage always remove the stator and store separately (at 15–20 °C).

3 Product description

The dispenser has been developed and tested for precision dosing of materials ranging from low to high viscosity with extremely high repeat accuracy.

preeflow dispensers are positive displacement pumps. The conveying elements comprise a rotating part, the "rotor", and a stationary part, the "stator". The rotor, which is in the form of a type of knuckle thread, rotates inside the stator, which has one more thread turn and twice the pitch length of the rotor. As a result, conveying areas are produced between the stator and the rotor rotating inside the stator. The rotor also moves radially within the stator.

The conveying spaces move forward continuously due to the movement. The flexible shaft used to drive the rotor compensates for the eccentric movement of the rotor and is completely maintenance-free.

The sealing effect of the conveying elements of the dispenser is dependent on the viscosity and pressure.

Since the direction of flow is reversible, the material can be sucked back to allow a clean thread break.

The dispenser can be dismantled very quickly.

Together with the eco-CONTROL EC200 DUO dosing control unit, the dispenser forms a dosing system which is typically installed in a dosing station. The dosing control unit controls the required parameters (e.g. dosing quantity, dosing speed, etc.).

4 Operation

4.1 Initial commissioning

All activities described below may only be carried out by qualified staff.

When delivered, the stator is not installed so as to avoid bearing damage to the elastomer of the stator.

4.1.1 Dismantling the dispenser

- ▶ Remove the 2 screws (9).
- ▶ Remove the locking plate (11).
- ▶ Remove screws (12).
- ▶ Remove the mix housing (10).
- ▶ Remove the seals (14).
- ▶ Remove the 4 screws (9).
- ▶ Remove the centring cover (8).

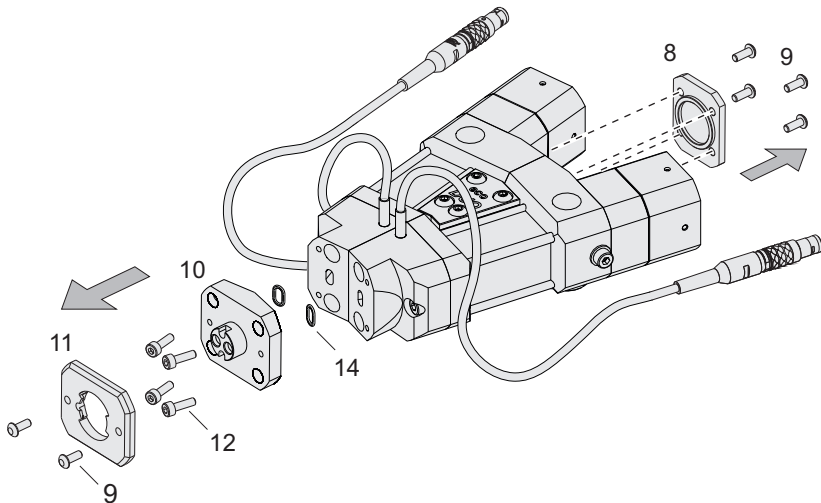

Fig. 2

- ▶ Remove the 4 screws (17).
- ▶ Remove the mounting plates (15, 16).
- ▶ Separate the dispenser halves.

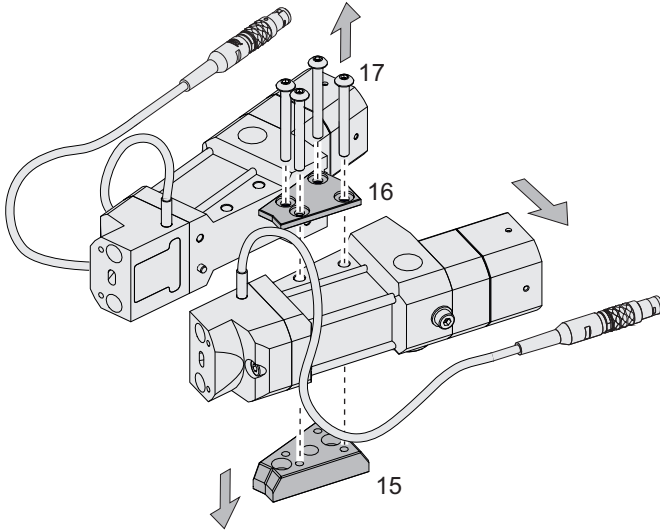

Fig. 3

On both dispenser halves perform

- ▶ Remove screws (6).
- ▶ Remove end piece (5B).

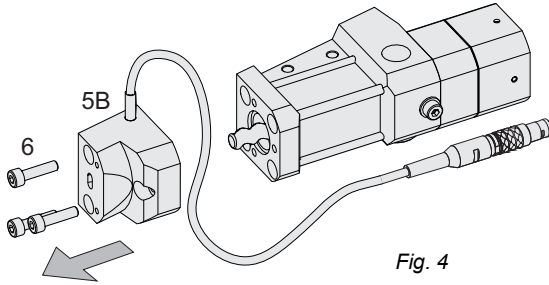

Fig. 4

4.1.2 Installing the stator

On both dispenser halves perform

- ▶ Plug the star-shaped coupling (22) into the rotor assembly seal housing (1).
- ▶ Plug the assembly aid (25) into the rotor assembly seal housing (1).
- ▶ Coat the rotor (26) with material or a suitable lubricant.
- ▶ Turn the stator (4) in the correct position (see detailed view) on the rotor (26) until the dowel pin (7) begins to dip into the keyway (3).
- ▶ Lightly press the stator towards the pump housing (2) and turn the assembly aid (25) in the direction of the arrow until the stator (4) has been guided into the pump housing (2).
- ▶ Uncouple the assembly aid (25).

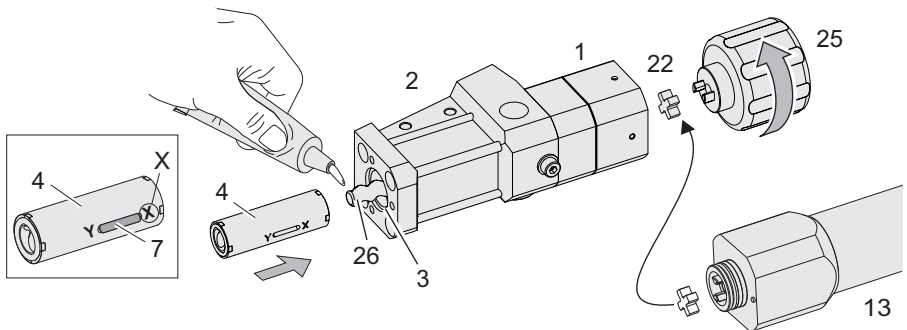

Fig. 5

4.1.3 Reassembling the dispenser

For reassembly, the work steps outlined in Section 4.1.1 (page 13) are carried out in reverse order.

When doing this, observe the following

- ▶ Join the end piece (5B) and the pump housing (2) in parallel so that the dispensers can be assembled suitably to each other.
- ▶ Tighten the screws (6).

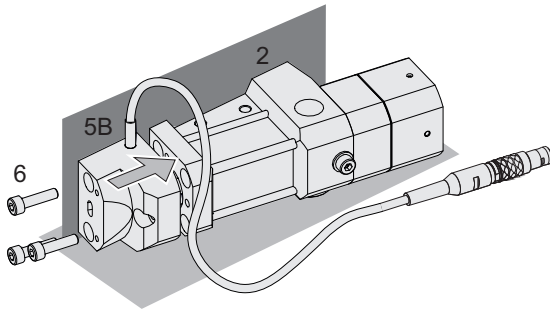

Fig. 6

NOTE

Carry out the assembly on an even surface.

Do not exceed a tightening torque of 0.5 Nm when mounting the screws.

4.1.4 Information on the sensors

The sensors are cast into the end piece. If the sensor is damaged, it cannot be replaced. A new end piece must be ordered.

Therefore, make sure that you are careful in handling these components.

Do not immerse the end piece (5A / 5B) in cleaning agent, rather simply wipe it clean. Only blunt, non-abrasive, soft implements should be used to clean the dosing channel, such as cloths/brushes.

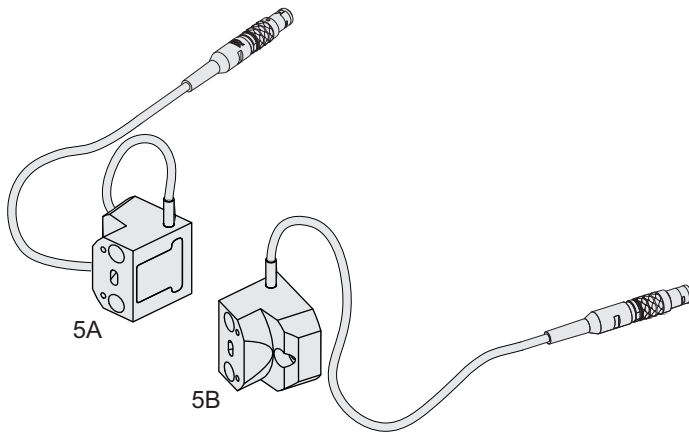

Fig. 7

4.1.5 Connecting the dosing unit to the drive unit

- ▶ Screw the set screws (21) into the thread so that they do not protrude into the coupling area.
Danger of damage to the fit.
- ▶ Attach the star-shaped couplings (22) onto the coupling of the drive units (A).
- ▶ Set the anti-rotation device (23) in the correct position relative to the dispenser.
- ▶ Fully assemble the dispenser with the drive units (A).
- ▶ Lightly screw in the set screws (21) to centre the drive units in the correct position.

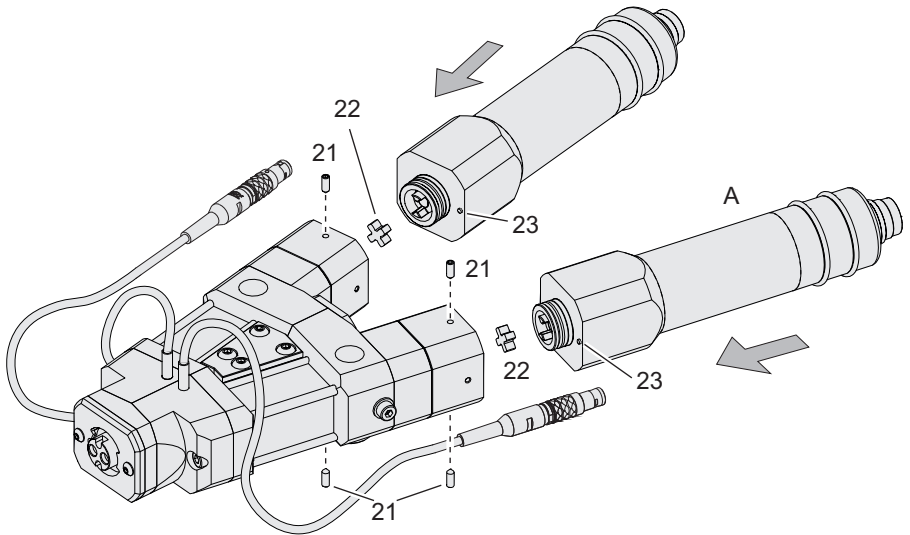

Fig. 8

4.1.6 Feeding material and bleeding the dispenser for the first time

- ▶ Connect the material supply (feed line, cartridge) to the material inlet (B) of the dispenser.
- ▶ Bring the eco-DUO600 into a vertical position.
- ▶ Position the static mixer (24) and lock in place.

On both dispenser halves perform

- ▶ Pressurise the material.
- ▶ Connect the drive unit to the power supply and run it slowly until material escapes from the static mixer (24) without bubbles.*
- ▶ Unscrew the bleed screw (27) and sealing washer (28) to bleed.
- ▶ Tighten the bleed screw (27) and the sealing washer (28) again.
- ▶ Remove leaking material with a cloth.

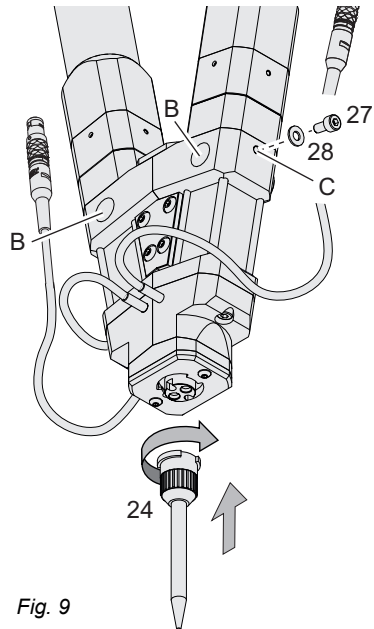

Fig. 9

Tip: Connecting a hose to the mixing pipe can protect the eco-DUO600 from being wetted with the material.

NOTE

When cleaning the dispenser, never use the same cloth for both materials, as the components will react.

* When filling for the first time, the blocking medium is first removed from inside the dispenser (stator).

4.1.7 Calibration

To obtain a precise dosing result, the dosing quantity must be calibrated. This is performed using the eco-CONTROL EC200 DUO dosing control unit. The exact procedure can be found in the dosing control unit manual.

A calibration adapter (35) is available for calibrating the dispenser. It is mounted on the outlet openings.

- ▶ Remove the static mixer.
- ▶ Unscrew the screws (9) in the locking plate (11).
- ▶ Mount the calibration adapter (35).
- ▶ Perform calibration according to the dosing control unit operation manual.
- ▶ Dismantle the calibration adapter (35).
- ▶ Tighten the screws (9) and locking plate (11).
- ▶ Position the static mixer.

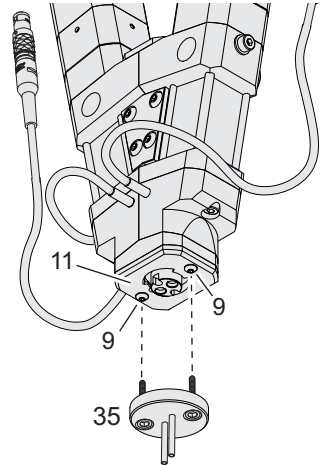

Fig. 10

4.2 Switching on, starting dosing process

Daily at the start of the shift / when starting work, perform the activities as described in Section 5.1 "Maintenance intervals" (page 24).

NOTE

The supply of material to the dispenser must be ensured before dosing starts.
Dry running may destroy the stator.

- ▶ Start supply of material to the dispenser.
- ▶ If present, remove cover.
- ▶ Switch on the dosing control unit.
- ▶ Dose the individual components (in manual operation) from the mixing head without static mixer. Use the calibration adapter (35) for this.
- ▶ Check whether both components escape without bubbles and that the outlet opening are not blocked or stuck together.
- ▶ Check the dosing quantity of each of the two components in order to guarantee a consistent dosing result. If there are deviations, dosing must be calibrated. The exact procedure can be found in the dosing control unit manual. The result of the check must be recorded together

with the name of the tester, date and time.

- ▶ Fit static mixer (24).
- ▶ Carry out at least one purge shot.
- ▶ Start dosing process via the dosing control unit.

4.3 Recommendations for problem-free operation

These experience values apply for a wide variety of dual-component materials. Always follow the manufacturer recommendations for your material in addition to these.

Mixing ratio for very short dosing times

Dual-component media display mostly varying properties (viscosity). They therefore emerge from the outlet openings with different pressures. This means that deviations in the mixing ratio can usually be noted at the start of dosing. Selecting a suitable mixing pipe is essential to the result.

Suck-back with dual-component materials

Suck-back ensures a clean thread break. If it is set too large, already mixed material enters the dosing pumps, causing them to react with each other. The max. suck-back volume is saved in the dosing control unit.

Note the pot life

During work breaks, purge shots prevent the mixed materials from hardening in the mixing pipe. The mixed materials are completely exchanged in the mixing pipe by the purge shot. A purge shot interval can be stored in the dosing control unit. The purge shot interval must be set so it is shorter than the pot life. This measure is not suitable for longer interruptions to production.

4.4 Switching off, ending dosing process

If the dosing process for a 2-component system has to be terminated, the outlet openings (A and B) have to be cleaned.

- ▶ Place dosing control unit in manual operation.
- ▶ Release the static mixer (24) from the mixing head and dispose of it in accordance with the material manufacturer's specifications.
- ▶ Clean the connection thread for the static mixer and holes (outlet openings). Ensure that the two components are not mixed.
- ▶ Hold the mixing head downwards and purge bores (A and B) individually. Catch any material leakage and clean the mixing head again. Ensure that the two components are not mixed. Use separate cloths.
- ▶ Switch off material supply to the dosing pump.
- ▶ Switch off dosing control unit and secure it against unauthorised restarting.
- ▶ Protect the connection thread and outlets against drying out and soiling, where necessary (e.g. with a cap and/or by applying lubricant* on the relevant areas). Follow the material manufacturer's instructions).

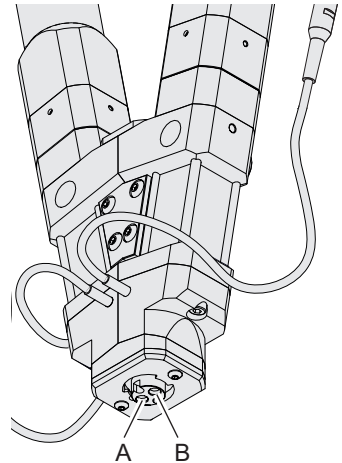

Fig. 11

* Recommendation: OKS-469, OKS, www.oks-germany.com

4.5 Decommissioning

All activities described below may only be carried out by authorised maintenance staff.

- ▶ Switch off the drive to the dispenser and lock it to prevent it from being switched on again.
- ▶ Shut down material supply to the dispenser (depressurise).
- ▶ Relieve inlet pressure via bleed screw.
- ▶ Remove material supply and seal openings with suitable plug.
- ▶ Disconnect the power supply to the drive units.
- ▶ Disconnect the dispenser and drive unit.
- ▶ Remove dispenser from holder or system.
- ▶ Remove the stator, clean and store separately.
- ▶ Disassemble and clean dispenser.
- ▶ Store dispenser according to the storage conditions as described in Section 2.8 "Transport and storage" (page 11).

4.6 Re-commissioning

Re-commissioning is the same as initial commissioning. The same specifications and work steps apply as described in Section 4.1 "Initial commissioning" (page 13). It must be ensured that the dispenser is free of medium residues, dust and dirt.

The stator must be installed before recommissioning (see Section 4.1.2 (page 15)).

5 Maintenance

In the event of a fault, or if there is any doubt that the machine/system is not completely ready for operation, it must be shut down immediately and inspected by competent maintenance staff before operation continues.

WARNING

Maintenance and cleaning work may only be carried out when the machine has been shut down safely and secured against unauthorised restarting. Otherwise, serious injuries may result.

- Switch off the dosing control unit.
- Disconnect the dosing control unit's power cable from the power supply

5.1 Maintenance intervals

In order to ensure problem-free operation, we recommend complying with the following maintenance intervals.

When	Activity	Who
Start of shift / daily	• Visual check for leaks / contamination / damage.	1
End of shift	• Clean the connection thread for the static mixer and outlets (A and B).	1
Every month	• Dismantle the end piece (5) and clean.	2
Every 6 months	• Remove drive and check star-shaped coupling.	2
Every year	• Disassemble the dispenser, clean and check all parts such as stator, rotor assembly, seals, bearings and housing and replace if required.	2

1 = Operating staff

2 = Maintenance staff

The recommended change cycles are based on empirical values for dosing applications. The empirical values are based on different material properties, pressure conditions and dosing settings. Depending on the material used, the required change cycles may differ from the recommended cycles.

Ambient conditions, such as temperature and humidity, may affect the change cycles.

5.2 Troubleshooting

Fault	Possible cause	Action
No or too little material feeding	Motor not connected	Connect the motor
	Fault with mains supply	Check electrical installation
	Material hardened/set	Dismantle and clean the dispenser
	Static mixer blocked	Replace the static mixer
	Stator/rotor worn	Replace stator/rotor
	Stator swollen	Check resistance of the stator to the material and replace stator
	Revolution too low	Correct revolution
	Inadequate supply of material	Feed material, check inlet pressure and correct if required
Dripping or running on of material	Suck-back not set correctly	Adjust the suck-back
	Air bubbles in the material	Bleed dispenser / material pipes
	Material compressible	Degas the material
Pressure too high, pressure sensor triggers	Dispenser speed too high	Reduce speed
	Pump speed too high in relation to the material or static mixer	Reduce speed
	Material hardened/set	Dismantle and clean the dispenser

If you have any questions about commissioning, maintenance, repairs or ways to optimise your processes, our Service employees will be happy to help.

You can reach us at: support@preeflow.com

We will respond to your service enquiry in German or English.

5.3 Stator change

All activities described below may only be carried out by authorised maintenance staff.

Preparation

- ▶ Disconnect the dosing control unit from the power supply.
- ▶ Disconnect the power supply to the drive units.
- ▶ Disconnect cable from the pressure monitor (if available).
- ▶ Shut down material supply (depressurise).
- ▶ Relieve inlet pressure via bleed screw.
- ▶ Remove material supply and seal openings with suitable plug.
- ▶ Disconnect the dispenser and drive unit.
- ▶ Remove dispenser from holder or system.
- ▶ Disassemble the dispenser as described in Section 4.1.1 (page 13).

On both dispenser halves perform

- ▶ Plug the star-shaped coupling (22) into the rotor assembly seal housing (1).
- ▶ Plug the assembly aid (25) into the rotor assembly seal housing (1).
- ▶ Unscrew stator (4) with assembly aid (25).

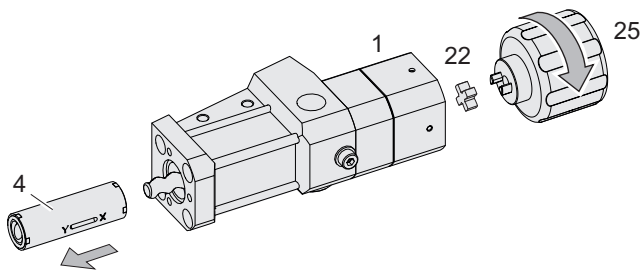

Fig. 12

Assembly

- ▶ Install the stator as described in Section 4.1.2 (page 15).
- ▶ Assemble the dispenser as described in Section 4.1.3 (page 16).

5.4 Dismantling before cleaning

When cleaning the dispenser, attention must be paid to the chemical properties and chemical reactions of the material. In doing so, observe and comply with the corresponding specifications of the product data sheet. If you have any queries, contact the manufacturer of the material.

All activities described below may only be carried out by authorised maintenance staff.

Preparation

- Remove the stator as described in Section 5.3 (page 26).

Removing the rotor assembly

- ▶ Unscrew the bleed screw (27) with washer (28).
- ▶ Unscrew plug (18).
- ▶ Remove the 4 screws (3).
- ▶ Remove the pump housing (2) and O-ring (26).

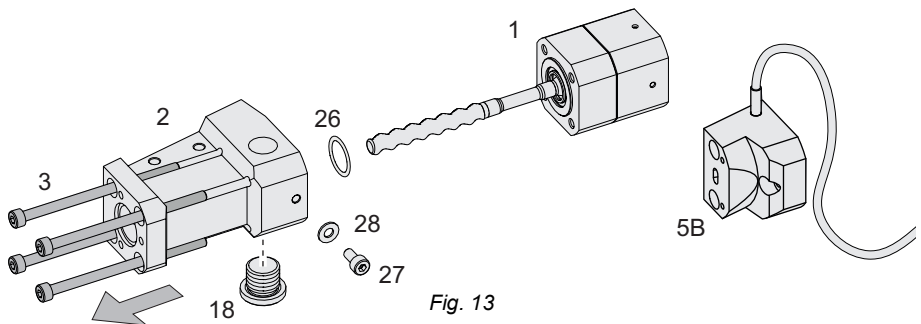

Fig. 13

NOTE

Do not purge the rotor assembly seal housing (1). This can damage the bearings!
Clean it only with a cloth and brush.

Do not immerse the end piece (5B) in cleaning agent, rather simply wipe it clean.
Only blunt, non-abrasive, soft implements should be used to clean the dosing channel, such as cloths/brushes.

Assembly

After cleaning, the dispenser is assembled in reverse order.

6 Cleaning

WARNING

Cleaning work may only be carried out when the machine has been shut down safely and secured against unauthorised restarting. Otherwise, serious injuries may result.

- Switch off the dosing control unit.
- Disconnect the dosing control unit's power cable from the power supply

If the dispenser is soiled with material or if the dispenser is disassembled and cleaned, use a cleaning agent which matches the material. The information in the safety data sheet must be complied with.

Recommended cleaning agents, e.g. cellulose thinner, cleaner's solvent or alcohol.

Note the following points regarding the use of cleaning agents and the performance of cleaning work:

- Observe the specifications in the safety data sheet for the cleaning agent
- Personal protective equipment must be worn
- Compatibility with the materials installed in the pump must be checked before use
- The cleaning agent must be used according to the manufacturer's specifications (e. g. application time)
- Cleaning agents must not penetrate electrical or mechanical system components
- Do not use high-pressure cleaners for cleaning
- Completely remove cleaning agent again
- Dispose of cleaning agent properly
- Re-attach any protective and safety devices or cladding removed and check that they function correctly
- Use a metal-free tool (do not use steel wool or a screwdriver)

7 Spare parts

Every time you order spare parts, please state the type identifier, serial number and order number.

The serial number is engraved on the bearing housing (31).

7.1 Item list of the spare parts

Items that are **not** shown in the overview drawing (Page 31)

Item	Description	X	pcs	Part No.	Material
	eco-DUO600 complete, with drive			21175	
	eco-PEN connection cable, complete (1.5 m)		2	20784	
	eco-DUO600 without drive		1	21168	
42	Allen wrench size 1.5		1	20203	
43	Allen wrench size 2.0		1	20491	
44	Screw driver size 2.5 (hexagon socket head)		1	20204	
45	Screw driver size 3.0 (hexagon socket head)		1	20205	

SPARE PARTS

Items that are shown in the overview drawing (Page 31)

Item	Description	X	pcs	Part No.	Material
1	Rotor strand seal housing		2	21152	
2	Pump housing		2	21153	Aluminium
3	Allen screw M4 x 70		8	21156	A2
4	Stator	X	2	20002	VisChem
5A	End piece, left with pressure sensor		1	21165	
5B	End piece, right with pressure sensor		1	21166	
6	Allen screw M4 x 16		6	20124	A2
8	Top centring cover		1	21155	Aluminium
9	Oval head screw M3 x 8		6	20487	A2
10	Mix housing		1	21163	Aluminium
11	Locking plate		1	21164	Aluminium
12	Allen screw M3 x 10		4	20390	A2
13	Drive unit		2	20047	
14	Seal	X	2	21167	FFKM
15	Fastening set (set, with 2 rear plates)		1	21172	Aluminium
17	Oval head screws M4 x 35		4	21147	A2
18	Plug G1/4 with O-ring (FKM)		2	21159	Stainless steel
21	Set screw M3 x 5		4	20088	A2
22	Star-shaped coupling	X	2	20050	Elastomer
24	Mixer (3-piece set)		1	21181	
25	Assembly aid		1	20108	PA 6
26	O-ring 13 x 1.25	X	2	20011	FFKM
27	Allen screw M4 x 8	X	2	20026	A2
28	Washer A 4.3	X	2	20027	PA 6
29	Sealing set with housing		2	21197	
30	O-ring 16 x 1.25	X	2	20007	FKM
31	Bearing housing with rotor assembly, complete		2	20152	
32	Allen screw M4 x 25		8	20031	A2
35	Calibration adapter		1	21180	

X = Recommended spare parts and wearing parts

To avoid costly downtime, we recommend keeping a stock of spare and wearing parts.

7.2 Overview drawing of the spare parts

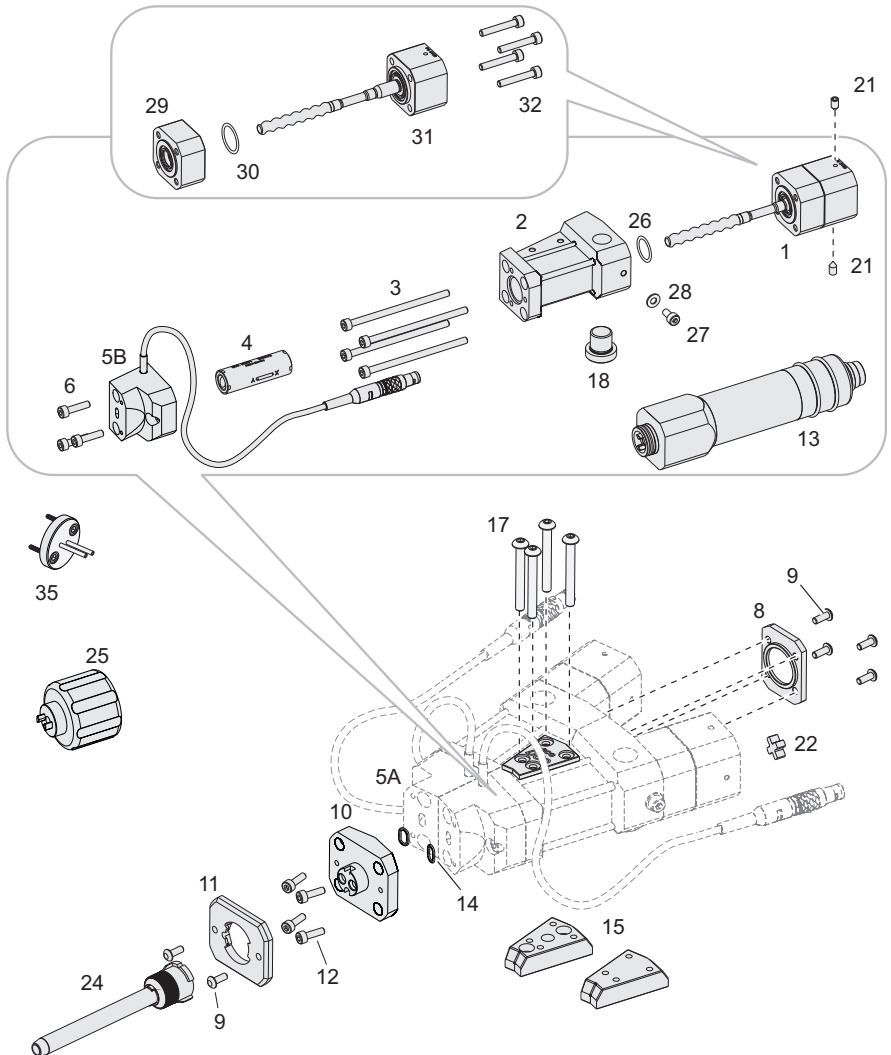

Fig. 14

8 Technical specifications

8.1 Installation declaration

Within the meaning of EU Directive 2006/42/EU on Machinery Annex II B

We,

ViscoTec Pumpen- u. Dosiertechnik GmbH
Amperstraße 13
D-84513 Töging am Inn,

hereby declare that, in the design and manufacture of the incomplete machine described below, the following basic requirements of EU Directive 2006/42/EC have been applied and complied with: 1.1.2, 1.1.3, 1.1.5, 1.3.2, 1.5.4, 1.6.1, 1.6.2, 1.7.4, 1.7.4.1, 1.7.4.2

We declare in addition that the special technical documents were drawn up in accordance with Annex VII part B of this Directive. Where applicable, the incomplete machine corresponds in addition to the stipulations of Directives 2014/35/EC on electrical equipment and 2014/30/EC on electromagnetic compatibility.

Product designation: eco-DUO600

We undertake to convey to the market supervisory authorities, at their justifiable request, the special documents concerning the incomplete machine in electronic form via our documentation department.

The incomplete machine may only be put into operation once it has been determined, as required, that the machine or unit into which the incomplete machine is to be installed complies with the stipulations of Directive 2006/42/EC on machinery and that the EU Declaration of Conformity has been produced in accordance with Annex II A.

Töging am Inn, 04 February 2020



Martin Stadler
Managing Director and authorised representative

8.2 Technical data

eco-DUO600	
Weight	approx. 1,880 g
Minimum operating pressure	0 bar, with self-levelling liquid
Maximum operating pressure	20 bar, with non self-levelling liquid
Maximum dosing pressure ^{1) 4)}	40 bar
Self sealing ¹⁾	approx. 2 bar (reference material approx. 1000 mPas at 20 °C)
Motor	18 to 24 V DC, incremental encoder, planetary gear
Protection class according to DIN EN 60529	IP54
Sound level, (dB(A))	< 70
Operating conditions	+10 ° to +40 °C, air pressure 1 bar, relative humidity less than 60% (non-condensing)
Material temperature	+10 °C to +40 °C
Storage conditions	see page 11
Dosing volume, approx.	0.014 ml/U per dispenser
Dosing accuracy ²⁾	± 1 %
Repeatability	> 99 %
Mixing ratio	1:1 to 10:1
Minimum dosing quantity	0.03 ml
Volume flow ³⁾	0.6 to 32.0 ml/min

¹⁾ Max. dosing pressure and self-sealing decrease with decreasing viscosity and increase with increasing viscosity. Consult with the manufacturer.

²⁾ Volumetric dosing as absolute deviation relative to one dispenser rotation. Depending on the viscosity of the dosing material.

³⁾ Max. volume flow is dependent on the viscosity, inlet pressure and mixing ratio.

⁴⁾ Dependent on the mixing pipe.

Threads used	
Material inlet	1/4" cylindrical Whitworth pipe thread DIN/ISO 228
Bleed hole	M4 x 8 DIN 13
Static mixer	Bayonet catch

8.3 Materials used

Components in contact with the material	Material
2-component dispenser housing, end nozzle	Anodized aluminium
2-component dispenser parts, motor housing	Anodized aluminium
Screws, washers, etc.	Stainless steel A2
Stator elastomer, flexible shaft covering	VisChem
Shaft sealing rings	Z80
O-rings	FKM, FFKM
Drive shaft, rotor	Stainless steel 1.4404

8.4 Dimensions

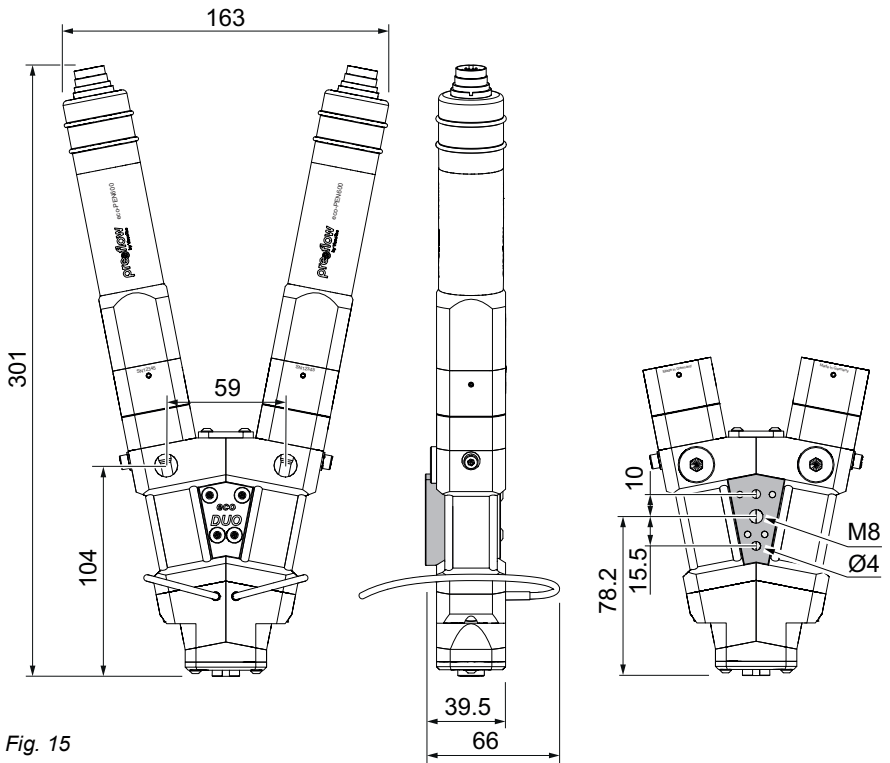

9 Disposal

The dispenser must be removed by competent maintenance staff.

Disposal may only be performed in line with the currently applicable, country-specific specifications, standards and legislation.

Ensure environmentally friendly recycling of all materials.

Electrical parts must not be disposed of with household waste (2012/19/EU).

They must be taken to the collection points provided for this purpose or disposed of in an environmentally appropriate way.

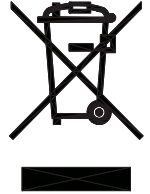

10 Accessories

In addition to the standard spare parts listed in Section 7.1 (page 29), special solutions are available upon request, for example

- Conversion kit in stainless steel
- Rotor/stator in alternative materials
- Fastening elements
- Process connections

Furthermore, we can offer you a comprehensive range of consumables, such as:

- Dosing needles
- Mixers

Please contact us if required: info@preeflow.com



© Copyright 2020

ViscoTec Pumpen- u. Dosiertechnik GmbH
Amperstraße 13
D-84513 Töging am Inn
Germany

This document is protected by copyright. It must not be modified, extended, reproduced or distributed to third parties without written consent.

Subject to technical and editorial change.

Translation of original operation manual

Document no. / Version
INST-002742 / B